

15 kW

EcoGen™

Variable Speed Residential Standby Generator Air-Cooled Gas Engine

INCLUDES:

- G-Flex™ Variable Speed Technology
- Designed specifically for use with alternative energy and storage solutions
- Two Line LCD Multilingual Digital Evolution™ Controller (English/Spanish/French/Portuguese)
- Electronic Governor
- External Main Circuit Breaker, System Status & Maintenance Interval LED Indicators
- GFCI Duplex Outlet
- Sound Attenuated Enclosure
- Flexible Fuel Line Connector
- Composite Mounting Pad
- Protective Base Fascia
- Natural Gas or LP Gas Operation
- 3 Year, 2000 Hour Limited Warranty
- Capability to be installed within 18" (457 mm) of a building**

Standby Power Rating

Model 006103-0 (Aluminum - Gray) - 15 kW 60 Hz



*Built in the USA using domestic and foreign parts



Not for sale in California

**Only if located away from doors, windows and fresh air intakes, and unless otherwise directed by local codes.

FEATURES

- **INNOVATIVE DESIGN & PROTOTYPE TESTING** are key components of GENERAC'S success in "IMPROVING POWER BY DESIGN." But it doesn't stop there. Total commitment to component testing, reliability testing, environmental testing, destruction and life testing, plus testing to applicable CSA, NEMA, EGSA, and other standards, allows you to choose GENERAC POWER SYSTEMS with the confidence that these systems will provide superior performance.
- **G-FLEX VARIABLE SPEED TECHNOLOGY:** By utilizing patented variable speed technology, the generator is capable of running at various RPMs depending on the electrical demand, resulting in quieter operation, better fuel economy and produce power at <2% total harmonic distortion for quality power.
- **EXTENDED RUN CAPABILITY.** This innovative oil circulation system extends the maintenance intervals by an unprecedented 5 times the industry standard by offering 500 hour maintenance intervals.
- **TEST CRITERIA:**
 - ✓ PROTOTYPE TESTED
 - ✓ NEMA MG1-22 EVALUATION
 - ✓ SYSTEM TORSIONAL TESTED
 - ✓ MOTOR STARTING ABILITY
- **SOLID-STATE, FREQUENCY COMPENSATED VOLTAGE REGULATION.** This state-of-the-art power maximizing regulation system is standard on all Generac models. It provides optimized FAST RESPONSE to changing load conditions and MAXIMUM MOTOR STARTING CAPABILITY by electronically torque-matching the surge loads to the engine. Digital voltage regulation at ±1%.
- **SINGLE SOURCE SERVICE RESPONSE** from Generac's extensive dealer network provides parts and service know-how for the entire unit, from the engine to the smallest electronic component.
- **PURPOSE BUILT FOR RENEWABLE ENERGY APPLICATIONS.** Designed specifically to interact with off-grid renewable energy applications, Generac introduces the first generator intended for alternative energy interaction. Capable of tying into an inverter and battery storage system to supplement the alternative energy source. This provides the cleanest running, low emission solution to recharging house batteries.

15 kW

Engine

- Generac (OHVI) design Maximized engine “breathing” for increased fuel efficiency. Plateau honed cylinder walls and plasma moly rings help the engine run cooler, reducing oil consumption resulting in longer engine life.
- “Spiny-lok” cast iron cylinder walls Rigid construction and added durability provide long engine life.
- Electronic ignition/spark advance These features combine to assure smooth, quick starting every time.
- Oil circulatory system Extends maintenance intervals to 500 hours and virtually eliminates oil degradation.
- Full pressure lubrication system Pressurized lubrication to all vital bearings means better performance, less maintenance and longer engine life. Now featuring up to a 2 year/500 hour oil change interval.
- Low oil pressure shutdown system Shutdown protection prevents catastrophic engine damage due to low oil.
- High temperature shutdown Prevents damage due to overheating.
- Optimized muffler and resonator Results in dramatically quieter operation during normal loads than constant speed systems.

Generator

- Cylindrically wound rotor Allows for multi-phase excitation, enabling variable engine RPM resulting in fuel savings and sound reduction.
- Skewed stator Produces a smooth output waveform for compatibility with electronic equipment.
- Variable speed, constant frequency AVR Provides uncommonly clean power with less than 2% THD (Total Harmonic Distortion)
- Automatic voltage regulation Regulates the output voltage to $\pm 1\%$ prevents damaging voltage spikes.
- UL 2200 listed For your safety.

Evolution™ Controls

- Auto/Manual/Off illuminated buttons Selects the operating mode and provides easy, at-a-glance status indication in any condition.
- Sealed, raised buttons Smooth, weather-resistant user interface for programming and operations.
- 2-wire Start Interconnection Allows the generator to be started by a two wire signal.
- Smart battery charger Delivers charge to the battery only when needed at varying rates depending on outdoor air temperature.
- Main line circuit breaker Protects generator from overload.
- Electronic governor Maintains constant 60 Hz frequency.

Unit

- Weather protective enclosure Ensures protection against mother nature and can withstand winds up to 150mph. Hinged key locking roof panel for security. Lift-out front for easy access to all routine maintenance items. Electrostatically applied textured epoxy paint for added durability.
- Enclosed critical grade muffler Quiet, critical grade muffler is mounted inside the unit to prevent injuries.
- Small, compact, attractive Makes for an easy, eye appealing installation.
- SAE Sound attenuated enclosure ensures quiet operation.

Installation System

- 1 ft (305 mm) flexible fuel line connector Easy installation.
- Composite mounting pad

15 kW

Generator

Model	006103-0
Rated Maximum Continuous Power Capacity (LP)	15,000 Watts*
Rated Maximum Continuous Power Capacity (NG)	15,000 Watts*
Rated Voltage	240
Rated Maximum Continuous Load Current – 240 Volts (LP/NG)	62.5/62.5
Total Harmonic Distortion	Less than 2%
Main Line Circuit Breaker	65 Amp
Phase	1
Number of Rotor Poles	2
Rated AC Frequency	60 Hz
Power Factor	1.0
Battery Requirement (not included)	Group 26R, 12 Volts and 525 CCA Minimum
Unit Weight (lb/kg)	536/243
Dimensions (L x W x H) in/mm	48 x 25 x 29/1218 x 638 x 732
Sound output in dB(A) at 23 ft (7 m) with generator operating at normal load**	63

Engine

Type of Engine	GENERAC OHVI V-TWIN	
Number of Cylinders	2	
Displacement	999 cc	
Cylinder Block	Aluminum w/ Cast Iron Sleeve	
Valve Arrangement	Overhead Valve	
Ignition System	Solid-state w/ Magneto	
Governor System	Electronic	
Compression Ratio	9.5:1	
Starter	12 Vdc	
Oil Capacity Including Filter	Approx. 3.75 qt/3.55 L	
Operating rpm	2,700-3,600	
Fuel Consumption		
Natural Gas	ft ³ /hr (m ³ /hr)	
	1/2 Load	134 (3.79)
	Full Load	281 (7.96)
Liquid Propane	ft ³ /hr (gal/hr) [l/hr]	
	1/2 Load	47.61 (1.32) [4.99]
	Full Load	104.4 (2.87) [10.86]

Note: **Fuel pipe must be sized for full load.** Required fuel pressure to generator fuel inlet at all load ranges - 3.5-7" water column (7-13 mm mercury) for natural gas, 10-12" water column (19-22 mm mercury) for LP gas. For Btu content, multiply ft³/hr x 2500 (LP) or ft³/hr x 1000 (NG). For Megajoule content, multiply m³/hr x 93.15 (LP) or m³/hr x 37.26 (NG).

Controls

2-Line Plain Text Multilingual LCD Display	Simple user interface for ease of operation.
Mode Buttons:	Automatic Start on Utility failure.
Auto	
Manual	Start with starter control, unit stays on. If utility fails, transfer to load takes place.
Off	Stops unit. Power is removed. Control and charger still operate.
Ready to Run/Maintenance Messages	Standard
Engine Run Hours Indication	Standard
Programmable start delay between 2-1500 seconds	Standard (programmable by dealer only)
Utility Voltage Loss/Return to Utility Adjustable	From 140-171 V/190-216 V
Future Set Capable Exerciser/Exercise Set Error Warning	Standard
Run/Alarm/Maintenance Logs	50 Events Each
Engine Start Sequence	Cyclic cranking: Engine cranks a maximum of five times at factory set intervals and durations.
Starter Lock-out	Starter cannot re-engage until 5 sec after engine has stopped.
Smart Battery Charger	Standard
Charger Fault/Missing AC Warning	Standard
Low Battery/Battery Problem Protection and Battery Condition Indication	Standard
Automatic Voltage Regulation with Over and Under Voltage Protection	Standard
Under-Frequency/Overload/Stepper Overcurrent Protection	Standard
Safety Fused/Fuse Problem Protection	Standard
Automatic Low Oil Pressure/High Oil Temperature Shutdown	Standard
Overcrank/Overspeed (@ 72 Hz)/rpm Sense Loss Shutdown	Standard
High Engine Temperature Shutdown	Standard
Internal Fault/Incorrect Wiring Protection	Standard
Common External Fault Capability	Standard
Field Upgradable Firmware	Standard

**Sound levels are taken from the front of the generator. Sound levels taken from other sides of the generator may be higher depending on installation parameters. Rating definitions - Standby: Applicable for supplying emergency power for the duration of the utility power outage. No overload capability is available for this rating. (All ratings in accordance with BS5514, ISO3046 and DIN6271). * Maximum wattage and current are subject to and limited by such factors as fuel Btu/megajoule content, ambient temperature, altitude, engine power and condition, etc. Maximum power decreases about 3.5 percent for each 1,000 feet (304.8 meters) above sea level; and also will decrease about 1 percent for each 6 °C (10 °F) above 16 °C (60 °F).

15 kW

Model #	Product	Description
005819-0	26R Wet Cell Battery	Every standby generator requires a battery to start the system. Generac offers the recommended 26R wet cell battery for use with all air-cooled standby product.
006212-0	Cold Weather Kit	If the temperature regularly falls below 32 °F (0 °C), a cold weather kit is required to maintain optimal battery and oil temperatures. Kit consists of battery warmer and oil filter heater with built-in thermostats.
005704-0	Paint Kit	If the generator enclosure is scratched or damaged, it is important to touch-up the paint to protect from future corrosion. The paint kit includes the necessary paint to properly maintain or touch-up a generator enclosure.
006829-0	Scheduled Maintenance Kit	Generac's scheduled maintenance kits provide all the hardware necessary to perform complete routine maintenance on a Generac automatic standby generator.

dimensions & UPC

Dimensions shown are approximate. Refer to installation manual for exact dimensions. DO NOT USE THESE DIMENSIONS FOR INSTALLATION PURPOSES.

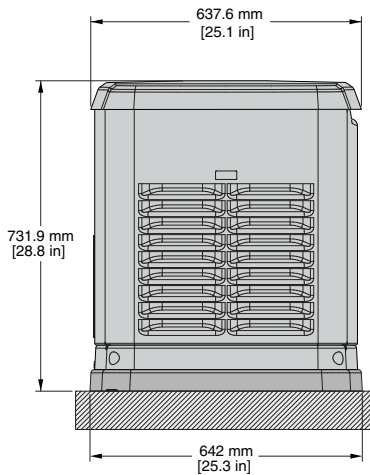

LEFT SIDE VIEW

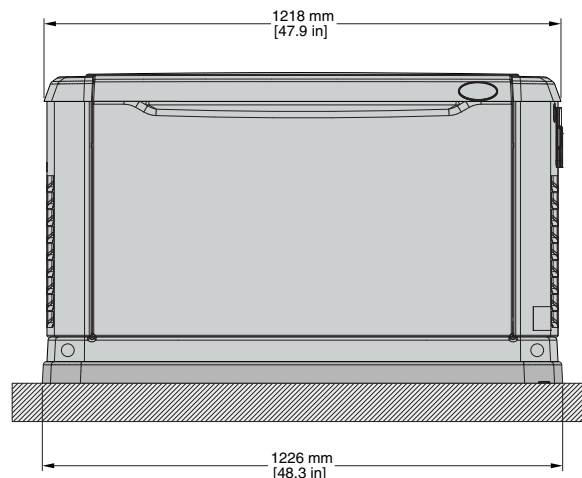

FRONT VIEW

Model	UPC
006103-0	696471061031